

ITEM NO.	PART NUMBER	QTY.
1	[AL100] - COPPER M5 ROD TX	1
2	[AL100] - 20MM COPPER DISC	1
3	[AL100] - 4 INCHES ALUMINIUM TUBE	1
4	[AL100] - 8mm ALUMINIUM END CAP BOTTOM	1
5	[AL100] - 8mm ALUMINIUM END CAP TOP	1
6	[AL100] - 8mm ALUMINIUM SOCKET WALL	1
7	[AL100] - 8mm ALUMINIUM TOP COVER	1
8	[AL100] - COPPER PLATE	1
9	[AL100] - COUPLING LOOP BAR TX (L)	1
10	[AL100] - COUPLING LOOP BAR TX (R)	1
11	[AL100] - 28mm COPPER CONDUCTOR TX	1
12	[AL100] - M3 X 6 HEX_SOCKET_CYLINDRICAL_HEAD	8
13	[AL100] - M4 X 14 HEX_SOCKET_BUTTON_HEAD	2
14	[AL100] - M4 X 14 HEX_SOCKET_COUNTERSUNK_FLAT_HEAD	5
15	[AL100] - M4 X 16 HEX_SOCKET_BUTTON_HEAD	3
16	[AL100] - M4 X 8 HEX_SOCKET_BUTTON_HEAD	16
17	[AL100] - M4 X 8 HEX_SOCKET_COUNTERSUNK_FLAT_HEAD	31
18	[AL100] - M5 NUT	1
19	[AL100] - M5 WASHER	1
20	[AL100] - N SOCKET	2
21	[AL100] - TEFLON GROMMET	2

PAWEL ROZENEK MOPPR
WWW.ROZENEK.COM

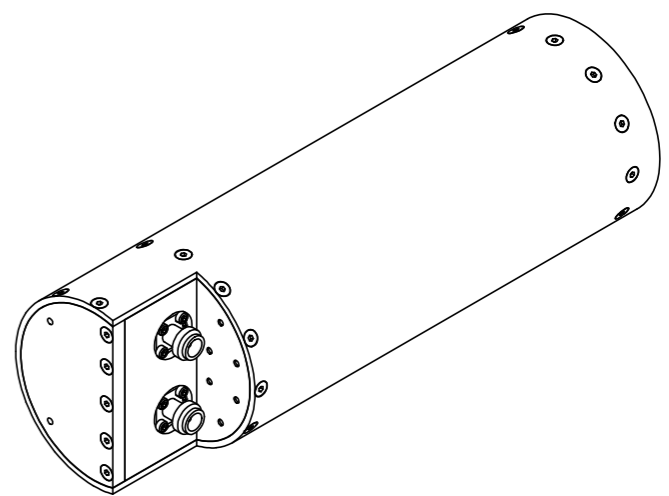

UNLESS OTHERWISE SPECIFIED: DIMENSIONS ARE IN MILLIMETERS		FINISH:		DEBURR AND BREAK SHARP EDGES		DO NOT SCALE DRAWING		REVISION 3	
SURFACE FINISH:									
TOLERANCES:									
LINEAR:									
ANGULAR:									
DRAWN MOPPR		SIGNATURE		DATE 30SEP2022		TITLE:			
CHK'D						430/439MHz DUPLEXER RX CAVITY BP-BR			
APP'VD						DWG NO.			
MFG						[AL100] - Cavity TX ^{A3}			
Q.A				MATERIAL:		SCALE:1:1.5		SHEET 1 OF 1	
				WEIGHT:					